

BARN CLEANER CHAINS

7/8 Logging Chain

- ✓ 7/8" diameter chain, 6" pitch length
- ✓ Sections are 21' 2" long
- ✓ 100% tested & pre-stretched at factory
- ✓ Ultimate strength and simplicity

S-86 Chain

- ✓ Formed round bar pintle link
- ✓ S-link provides large wear surface
- ✓ Sections are 10' 3" long
- ✓ Paddles are welded to pintle flat bar

Brutus Pintle Chain

- ✓ High strength forged link
- ✓ Dovetailed riveted pintle links
- ✓ Sections are 18" long
- ✓ Paddles are welded to pintle flat bar

Bolted Pintle Chain

- ✓ High strength forged link
- ✓ Dovetailed riveted pintle links
- ✓ Sections are 12 feet long
- ✓ Paddles are bolted to forged link



BARN CLEANERS



Visit our website for more information on these Jamesway products!

MANURE SYSTEMS:

- Alley Scrapers
- Vertical Electric Pumps
- Electric Prop Agitators
- Vertical PTO Pumps
- Piston Transfer Pumps
- Cross Gutter Systems
- Barn Cleaners

MANURE APPLICATION:

- Non-Steer Spreader Tanks
- Steerable Spreader Tanks
- Injection Systems
- Truck Mount Tankers
- Lagoon Pumps
- Prop Agitators
- Loading Pumps

FEEDING SYSTEMS:

- Silo Unloaders
- Feeders
- Conveyors
- Hammer Mills
- Power Feed Carts
- Bedding Choppers

Jamesway Farm Equipment products are designed in conformance to ASAE Standards S354.4 "Safety for Farmstead Equipment" and S318.15 "Safety for Agricultural Equipment". Some photos in this brochure have safety shields removed or open to show additional detail on equipment features. Never operate equipment without safety shields in place. Jamesway continually updates and improves products and reserves the right to make changes in the design, specifications, and to add improvements to our products, without incurring an obligation on equipment purchased.

JAMESWAY FARM EQUIPMENT, INC.
12 Route 249
St. Francois-Xavier (Quebec) JOB 2V0
Tele: (819) 845-7824
Fax: (819) 845-5153

DEALER:

JAMESWAY FARM EQUIPMENT, INC.
USA Warehouse
15383 State Hwy. 131
Tomah, WI 54660

MODEL 15/16 DRIVE UNITS

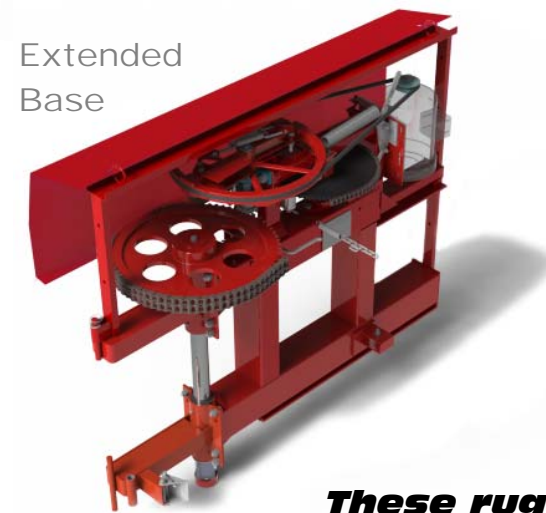

Easy to Own

- ✓ Massive main frame
- ✓ #80 roller chain final drive (Std unit)
- ✓ Double #80 roller chain final drive (HD unit)
- ✓ Rocker clutch for overload protection
- ✓ Insulated motor base

Easy to Use

- ✓ Automatic clutch reset
- ✓ Spring-loaded belt tightening
- ✓ UHMW tensioners
- ✓ Winch chain tightener
- ✓ Quick-release paddle wiper

Easy to Service

- ✓ Consists of 3 independent subassemblies
- ✓ Quick subassembly removal with 15/16" wrench
- ✓ Standard size bearings on 2 assemblies
- ✓ Nylatron bushings on final drive are easy to replace
- ✓ Low cost, easily available parts

These rugged Drive Units are built for the tough jobs.

ELEVATORS

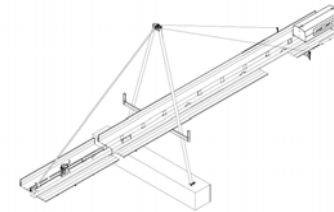

A-Frame Mount

- ✓ Model 2000 Rigid - 35 to 50 feet long
- ✓ Model 4000 Swinging - 40 to 85 feet long
- ✓ Cable supports for outer end
- ✓ Tie-rod stabilizer on A-Frame

Stand Mount

- ✓ Galvanized model up to 22 feet long
- ✓ Model 2000 Rigid up to 30 feet long

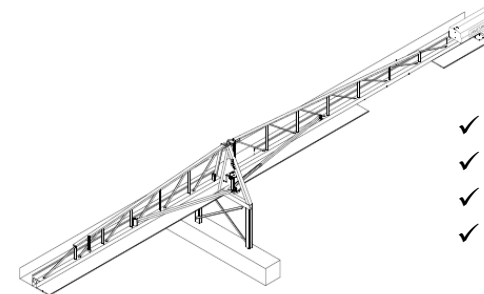

Single Truss

- ✓ Model 8800 - 45 to 85 feet long
- ✓ Self-supporting truss structure
- ✓ Swinging upper section
- ✓ Heavy duty stand

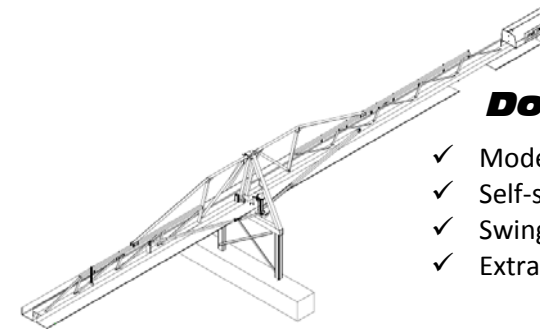

Double Truss

- ✓ Model 8500 - 55 to 85 feet long
- ✓ Self-supporting truss structure
- ✓ Swinging upper section
- ✓ Extra reach beyond heavy duty stand

Options

- ✓ Choice of wood or steel troughs
- ✓ Remote chain tightening
- ✓ Service platform
- ✓ Transmission mount kit

Models to fit every job and every budget.

SUPER 750 DRIVE UNITS

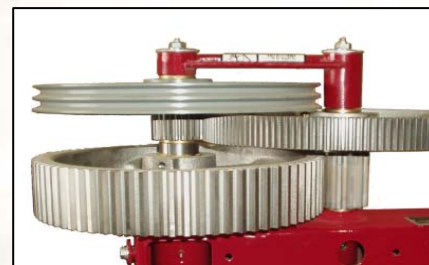

Easy to Maintain

- ✓ Long lasting gear drive
- ✓ No adjustment needed
- ✓ Shear bolt protection
- ✓ Extremely compact
- ✓ Up to 750 ft of chain

Durability & strength in a compact package.

ACCESSORIES



Wheels

- ✓ Round or sprocket wheels
- ✓ 12" diameter cast iron
- ✓ Floating box or anchored base mount
- ✓ Adjustable height
- ✓ Retrofit models to fit other brands



Other Accessories

- ✓ Transmission floor mount
- ✓ Transmission elevator adapters
- ✓ Anchor post and hold-down shoes
- ✓ Reverse curves
- ✓ Pre-fab corner forms

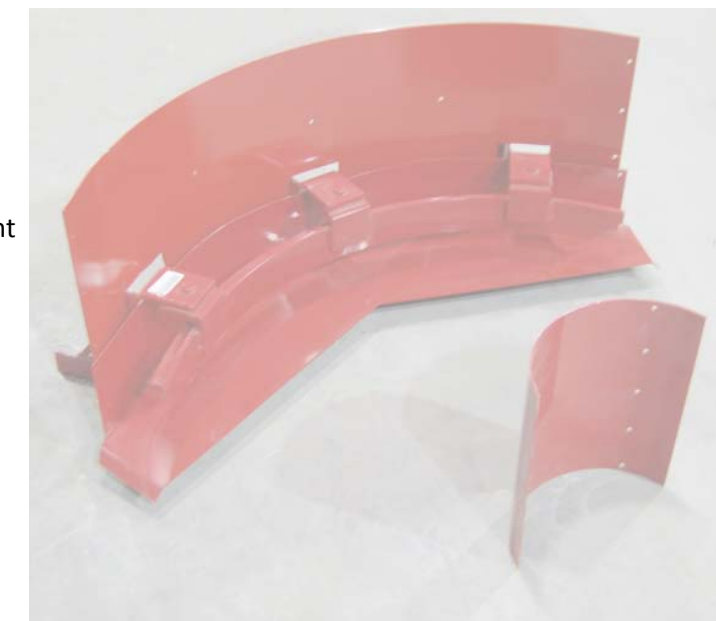

Quality accessories for a professional installation.